

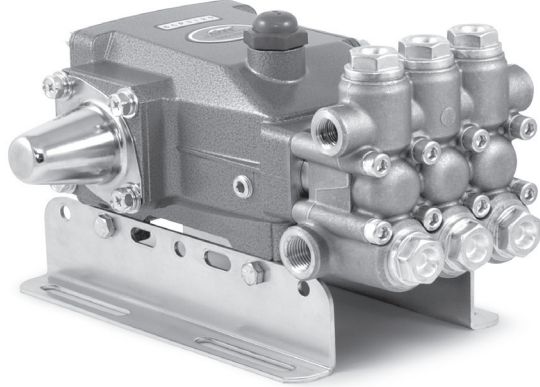

**PIJTERSEN**

E-mail : info@pijtersen.nl / info@catpumps.nl  
 Internet: www.pijtersen.nl / www.catpumps.nl



Model 5CP5120 Shown  
 (Rails and shaft protector sold separately)

**FEATURES**

- | Industrial triplex design offers reliability and versatility.
- | Ultra-compact footprint permits direct-drive to motor with bell housing and flexible coupling, direct-drive to engine with gearbox or belt drive for precision flow setting.
- | Optional EPDM and FPM elastomers for compatibility with many liquids.
- | Press-in seal cases and interchangeable valve assemblies for easy servicing.

**COMMON SPECIFICATIONS**

	U.S.	Metric
Inlet Pressure Range, Standard ...	-2.5 to 60 psi	(-2 to 4 bar)
Inlet Pressure Range, Alternate ...	10 to 60 psi	(1 to 4 bar)
Bore .....	0.709"	(18mm)
Crankcase Capacity.....	17 oz.	(0.51 l)
Max. Liquid Temperature .....	160°F	(71°C)
Above 130°F call CAT PUMPS for inlet conditions and elastomer recommendations.		
Inlet Ports (2) .....	1/2" NPTF	(1/2" NPTF)
Discharge Ports (2).....	3/8" NPTF	(3/8" NPTF)
Shaft Diameter .....	0.787"	(20 mm)
Dimensions (Pump Only).....	10.89 x 10.0 x 5.78"	(277 x 254 x 147mm)
Dimensions (w/gearbox) .....	10.5 x 12.4 x 6.4"	(267 x 315 x 162mm)

**CAUTIONS AND WARNINGS**

All High Pressure Systems require a primary pressure regulating device (i.e. regulator, unloader) and a secondary pressure relief device (i.e. pop-off valve, relief valve). Failure to install such relief devices could result in personal injury or damage to pump or property. CAT PUMPS does not assume any liability or responsibility for the operation of a customer's high pressure system.

Read all CAUTIONS and WARNINGS before commencing service or operation of any high pressure system. The CAUTIONS and WARNINGS are included in each service manual and with each Accessory Data sheet. CAUTIONS and WARNINGS can also be viewed online at www.catpumps.com/cautions-warnings or can be requested directly from CAT PUMPS.

**WARRANTY**

View the Limited Warranty on-line at [www.catpumps.com/warranty](http://www.catpumps.com/warranty).

**5CP Plunger Pump**

**Standard Models** 5CP5120  
5CP5140

**Gearbox Models** 5CP5140CSSG1

**SPECIFICATIONS**

U.S. Metric

**MODEL 5CP5120**

Flow .....	5.0 gpm	(19 lpm)
Pressure Range.....	100-3000 psi	(7-210 bar)
Pump RPM .....	1415 rpm	(1415 rpm)
Stroke.....	0.709"	(18 mm)
Weight.....	19.9 lbs.	(9 kg)

**MODEL 5CP5120 ALTERNATE SPECIFICATIONS**

Flow .....	6.0 gpm	(23 lpm)
Pressure Range.....	100-2500 psi	(7-170 bar)
Pump RPM .....	1750 rpm	(1750 rpm)
Inlet Pressure Range .....	10-60 psi	(1-4 bar)

**MODEL 5CP5140**

Flow .....	5.5 gpm	(21 lpm)
Pressure Range.....	100-3500 psi	(7-245 bar)
Pump RPM .....	1500 rpm	(1500 rpm)
Stroke.....	0.787"	(20 mm)
Weight.....	19.9 lbs.	(9 kg)

**MODEL 5CP5140CSSG1**

Flow .....	5.5 gpm	(21 lpm)
Pressure Range.....	100-3500 psi	(7-245 bar)
Pump RPM .....	1500 rpm	(1500 rpm)
Engine RPM .....	3060 rpm	(3060 rpm)
Stroke.....	0.787"	(20 mm)
Weight.....	26.5 lbs.	(12 kg)

**ELECTRIC HORSEPOWER REQUIREMENTS**

MODEL	FLOW		PRESSURE						MOTOR PULLEY SIZE	
			psi 1200	psi 1500	psi 2000	psi 2500	psi 3000	psi 3500	Using 1725 rpm Motor & 8" Std. Pump Pulley	
	u.s. gpm	lpm	bar 85	bar 110	bar 140	bar 175	bar 210	bar 245	rpm	Pulley O.D.
5CP5120	5.0	19	4.1	5.5	6.9	8.6	10.3	N/A	1415	6.5
ALTERNATE	6.0	23	4.9	6.2	8.2	10.3	N/A	N/A	1750	Direct
5CP5140	5.5	21	4.5	6.0	7.5	9.4	11.3	13.2	1500	6.9
5CP5140CSSG1	5.5	21	Consult Eng. Mfg.						3060	Gearbox

<b>DETERMINING THE PUMP RPM</b>	Rated gpm	=	"Desired" gpm
	Rated rpm	=	"Desired" rpm
<b>DETERMINING THE REQUIRED H.P.</b>	gpm x psi	=	Electric Brake H. P. Required
	1460	=	
<b>DETERMINING MOTOR PULLEY SIZE</b>	Motor Pulley O.D.	=	Pump Pulley O.D.
	Pump rpm	=	Motor rpm

See complete Drive Packages [Incls: Pulleys, Belts, Hubs, Key] Tech Bulletin 003. Refer to pump **Service Manual** for repair procedure and additional technical information.

# PARTS LIST

ITEM	PART NUMBER		DESCRIPTION		QTY	
	<b>5CP5140</b>					
	<b>5CP5120</b>	<b>MATL</b>	<b>5CP5140CSSG1</b>	<b>MATL</b>		
2	30057	STL	30057	STL	Key (M6x6x25)	1
5	96031	STZP	96031	STZP	Screw, HHC, Sems (M8x16)	8
	126542	STCP R	126542	STCP R	Screw, HHC, Sems (M8x16)	8
8	46910	AL	46910	AL	Cover, Bearing	2 - 1
10	14028	NBR	14028	NBR	O-Ring, Bearing Cover - 70D	2 - 2
11	43222	NBR	43222	NBR	Seal, Oil, Crankshaft - 70D	2 - 1
15	14480	STL	14480	STL	Bearing, Ball	2 - 2
20	48742	TNM	48742	TNM	Rod, Connecting Assy [10/01]	3
25	<b>46928</b>	<b>FCM</b>	—	—	Crankshaft, Dual End M18 - 5120	1
	—	—	<b>48646</b>	<b>FCM</b>	Crankshaft, Dual End M20 - 5140	1
	—	—	<b>49773</b>	<b>FCM</b>	Crankshaft, Single End M 20 - 5140CSSG1	1
30	—	—	<b>49776</b>	<b>AL</b>	Cover, Bearing - 5140CSSG1	1
	—	—	<b>48224</b>	<b>AL</b>	Cover, Bearing Blind - 5140G1 [prior to 12/10]	1
32	46798	—	46798	—	Cap, Oil Filler, Domed	1
33	14179	NBR	14179	NBR	O-Ring, Oil Filler Cap - 70D	1
37	92241	—	92241	—	Gauge, Oil, Bubble w/Gasket - 80D	2
38	44428	NBR	44428	NBR	Gasket, Flat, Oil Gauge - 80D	2
40	92519	STZP	92519	STZP	Screw, HHC, Sems (M6x16)	4
	125824	STCP R	125824	STCP R	Screw, HHC, Sems (M6x16)	4
48	25625	STCP	25625	STCP	Plug, Drain (1/4"x19BSP)	1
49	23170	NBR	23170	NBR	O-Ring, Drain Plug - 70D	1
50	46940	AL	46940	AL	Cover, Rear	1
51	14044	NBR	14044	NBR	O-Ring, Rear Cover	1
53	48617	AL	48617	AL	Crankcase	1
64	46746	CM	46746	CM	Pin, Crosshead	3
65	48458	BBNP	48458	BBNP	Rod, Plunger	3
70	46838	NBR	46838	NBR	Seal, Oil, Crankcase - 70D	3
75	43328	S	43328	S	Slinger, Barrier	3
88	45697	S	45697	S	Washer, Keyhole (M18x10)	3
90	49655	CC	49655	CC	Plunger (M18x50)	3
98	46730	NBR	46730	NBR	Washer, Seal - 90D	3
	48394	FPM	48394	FPM	Washer, Seal - 90D	3
	◆48432	EPDM	◆48432	EPDM	Washer, Seal	3
99	†48201	SS	†48201	SS	Retainer, Plunger w/Stud (M6)	3
100	46749	PVDF	46749	PVDF	Retainer, Seal	3
106	43243	NBR	43243	NBR	Seal, LPS w/S-Spg	3
	44926	FPM	44926	FPM	Seal, LPS w/SS-Spg	3
	◆46651	EPDM	◆46651	EPDM	Seal, LPS w/SS-Spg	3
	76243	ST2	76243	ST2	Seal, LPS w/S-Spg	3
120	49657	BB	49657	BB	Case, Seal (Press-in-style)	3
121	13978	NBR	13978	NBR	O-Ring, Seal Case - 70D	3
	14329	FPM	14329	FPM	O-Ring, Seal Case	3
	◆48904	EPDM	◆48904	EPDM	O-Ring, Seal Case	3
127	44549	SNG	44549	SNG	V-Packing	6
	45617	SFG	45617	SFG	V-Packing	6
	48300	STG	48300	STG	V-Packing	6
128	45618	BB	45618	BB	Adapter, Male	3
139	22179	BBCP	22179	BBCP	Plug, Inlet (1/2"NPTM)	1
163	17547	NBR	17547	NBR	O-Ring, Seat - 85D	6
	11685	FPM	11685	FPM	O-Ring, Seat - 85D	6
	◆46648	EPDM	◆46648	EPDM	O-Ring, Seat - 70D	6
164	45790	S	45790	S	Seat	6
166	46429	S	46429	S	Valve	6
167	43750	S	43750	S	Spring	6
168	†44565	PVDF	†44565	PVDF	Retainer, Spring	6
172	17549	NBR	17549	NBR	O-Ring, Valve Plug - 70D	6
	26996	FPM	26996	FPM	O-Ring, Valve Plug - 70D	6
	◆49133	EPDM	◆49133	EPDM	O-Ring, Valve Plug	6
173	48365	D	48365	D	Back-up-Ring, Valve Plug	6
174	45900	BB	45900	BB	Plug, Valve	6
185	46895	FBB	46895	FBB	Manifold, Head	1
188	126513	STCP R	126513	STCP R	Screw, HSH (M8x70)	8
196	22187	BBCP	22187	BBCP	Plug, Discharge (3/8"NPTM)	1
250	<b>118672</b>	<b>STCP</b>	<b>118672</b>	<b>STCP</b>	Protector, Shaft	1
255	30243	STZP	30243	STZP	Mount, Direct	1
260	<b>30611</b>	<b>STZP R</b>	<b>30611</b>	<b>STZP R</b>	Mount, Rail, Assy (4.22")	1
	<b>30613</b>	<b>STZP R</b>	<b>30613</b>	<b>STZP R</b>	Mount, Rail, Assy (5.02")	1
	<b>76513</b>	<b>STZP R</b>	<b>76513</b>	<b>STZP R</b>	Mount, Rail, Assy (5.52")	1
	<b>30637</b>	<b>STZP</b>	<b>30637</b>	<b>STZP</b>	Mount, Angle Assy-Retro Fit (See Tech Bulletin 078)	1
265	<b>30659</b>	—	<b>30659</b>	—	Kit, Complete Mounting (Incls: 30611, 30633, 118672) (Belt Drive Only)	1
275	30944	STL	30944	STL	Assembly, Hub & Key (Incls: 30945, 30057)	1

# EXPLODED VIEW

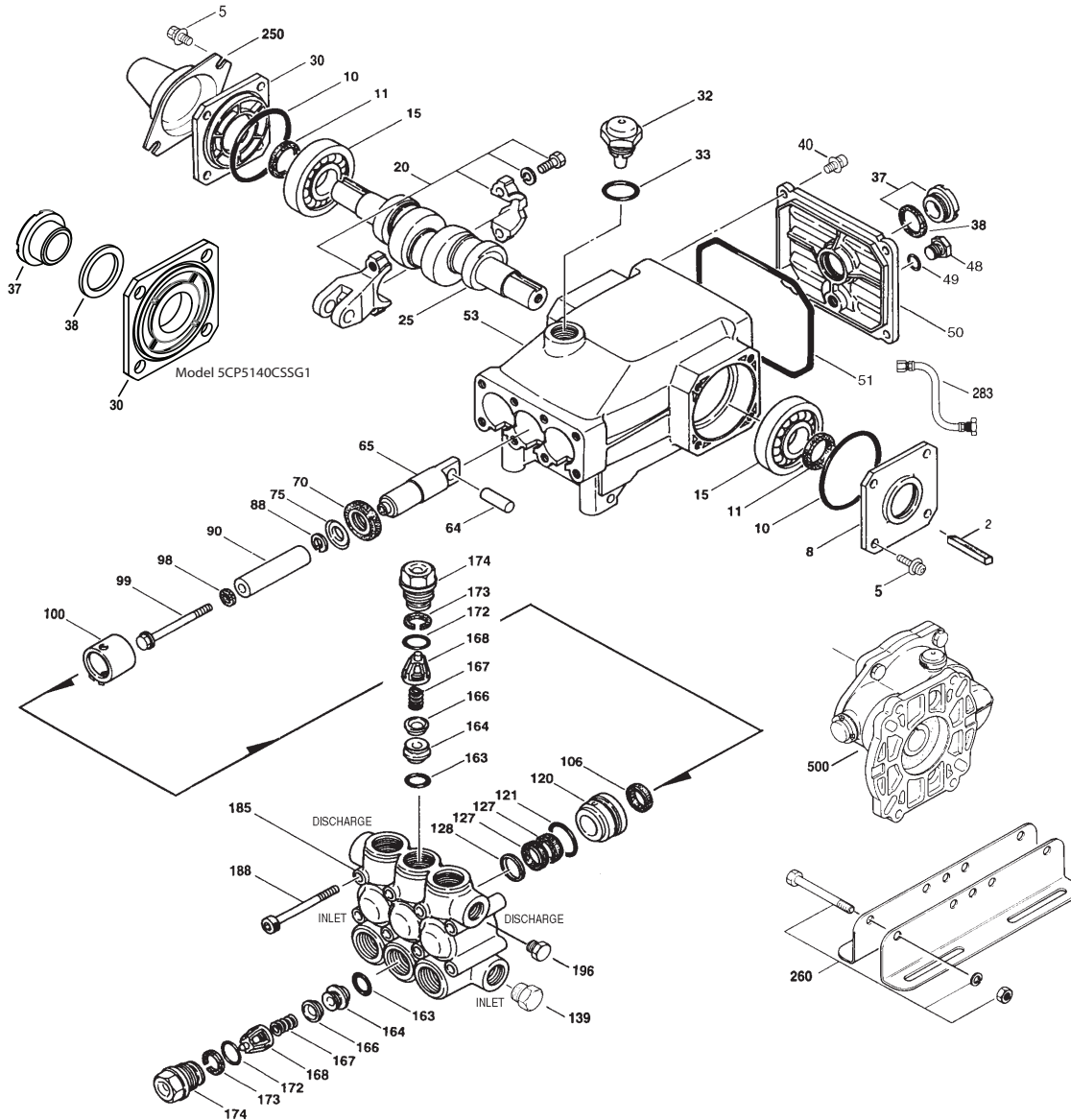

Models  
5CP5120, 5CP5140  
5CP5140CSSG1  
January 2013

		5CP5140				
	5CP5120	MATL	5CP5140CSSG1	MATL		
283	34334	—	34334	—	Kit, Oil Drain (3/8" x 24") (See Individual Data Sheet)	1
	76334	—	76334	—	Kit, Oil Indicator (3/8" x 24") (See Individual Data Sheet)	1
299	814844	FBB	814844	FBB	Head, Complete	1
300	33630	NBR	33630	NBR	Kit, Seal (Incls: 98,106,121,127)	1
	31350	FPM*	31350	FPM*	Kit, Seal (Incls: 98,106,121,127)	1
	76645	HT	76645	HT	Kit, Seal (Incls: 98,106,121,127)	1
	◆ 76630	EPDM	◆ 76630	EPDM	Kit, Seal (Incls: 98,106,121,127)	1
	76546	STHT	76546	STHT	Kit, Seal (Incls: 98,106,120,121,127) Prior to 2/09	1
	76960	STHT	76960	STHT	Kit, Seal (Incls: 98,106,121,127) After 2/09	1
310	33060	NBR	33060	NBR	Kit, Valve Preassembled (Incls: 163,164,166-168,172,173)	2
	31345	FPM	31345	FPM	Kit, Valve Preassembled (Incls: 163,164,166-168,172,173)	2
	◆ 31735	EPDM	◆ 31735	EPDM	Kit, Valve Preassembled (Incls: 163,164,166-168,172,173)	2
350	30696	STZP	30696	STZP	Pliers, Reverse	1
400	7850	BB	7850	BB	Modular Unloader (See Individual Data Sheet)	1
500	—	—	<b>8076</b>	—	Gearbox (See Individual Data Sheet)	1
—	6107	—	6107	—	Oil, Bottle (21 oz.) ISO 68 Hydraulic (Fill to specified crankcase capacity prior to start-up)	1

**Bold print part numbers are unique to a particular pump model.** *Italics are optional items.* [ ] Date of latest production change.

◆ Silicone oil/grease required. † Production parts are different than repair parts. R Components comply with RoHS Directive.

\*Review individual parts in each kit for material code identification.

View Tech Bulletins 002, 003, 024, 036, 043, 053, 060, 061, 064, 073, 074, 078 and 083 for additional information.

MATERIAL CODES (Not Part of Part Number): AL=Aluminum BB=Brass BBCP=Brass/Chrome Plated BBNP=Brass/Nickel Plated CC=Ceramic  
CM=Chrome-moly D=Acetal EPDM=Ethylene Propylene Diene Monomer FBB=Forged Brass FCM=Forged Chrome-moly FPM=Fluorocarbon  
HT=Hi-Temp (EPDM Alternative) NBR=Medium Nitrile (Buna-N) NY=Nylon PTFE=Pure Polytetrafluoroethylene PVDF=Polyvinylidene Fluoride S=304SS SS=316SS  
SNG=Special Blend (Buna) SFG=Special Blend (FPM) STG=Special Blend PTFE White ST2=Special Blend PTFE Grey STL=Steel  
STCP=Steel/Chrome Plated STZP=Steel/Zinc Plated TNM=Special High Strength

